

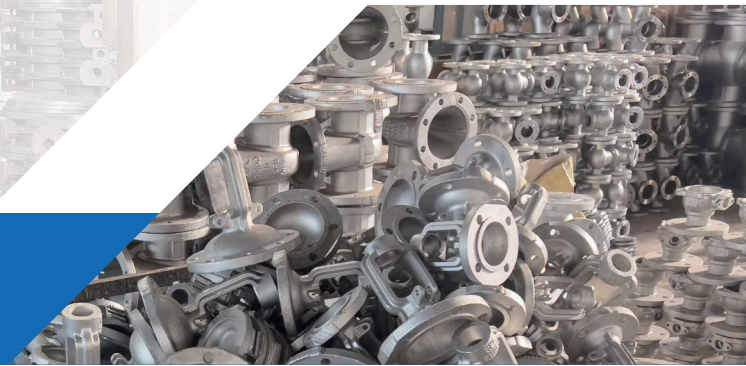

伟赛尔  
VINCER VALVE  
VALVE AUTOMATION TECHNOLOGY



## 电动硬密封蝶阀

VE20-HA VINCER ELECTRIC HARD-SEATED BUTTERFLY VALVE

# 电动硬密封蝶阀

## VE20-HA VINCER ELECTRIC HARD-SEATED BUTTERFLY VALVE



电动硬密封蝶阀采用耐高温、耐磨损的硬质密封材料，适用于高温高压下的流体控制。  
Electric hard-seated butterfly valve adopts high-temperature-resistant and wear-resistant hard sealing materials and is suitable for fluid control under high temperature and high pressure.



### 技术规范 Technical Parameter

- 设计标准 Design Standard: GB/T 12237、API 608、API 6D
- 结构长度 Face To Face Dimension: GB/T 12221、ASME B16.10、API 6D
- 连接法兰尺寸 Connecting Flange Size: GB/T 9113、HG20592、JB/T 79、GB/T 12224、ASME B16.5、ASME B16.47、ASME B16.11、ASME B16.25
- 试验和检验 Test & Inspection: JB/T 9092、GB/T 26480、API598、API 6D

### 优势 Advantage

耐磨损，自动化控制，高密封性

Wear resistance, Automatic control, High sealing

### 主要零件材质表 Main Parts Materials

序号 No.	零件名称 Component	材质 Material		
		C	P	R
1	内六角螺钉 Inner Hexagon Screw	1Cr18Ni9Ti	1Cr18Ni9Ti	1Cr1812Mo2Ti
2	阀盖 Bonnet	WCB	1Cr18Ni9Ti	ZG1Cr18Ni12Mo2Ti
3	垫片 Gasket	1Cr18Ni9Ti	1Cr18Ni9Ti	1Cr1812Mo2Ti
4	阀座 Seat	不锈钢+柔性石墨 PTFE Stainless Steel+Graphite PTFE		
5	垫片 Gasket	1Cr18Ni9Ti	1Cr18Ni9Ti	1Cr1812Mo2Ti
6	蝶阀板 Butterfly Plate	WCB	ZG1Cr18Ni9Ti	ZG1Cr18Ni12Mo2Ti
7	圆柱销 Straight Pin	45	1Cr18Ni9Ti	1Cr1812Mo2Ti
8	下盖 Bottom Cover	WCB	ZG1Cr18Ni9Ti	ZG1Cr18Ni12Mo2Ti
9	垫片 Gasket	不锈钢+柔性石墨 PTFE Stainless Steel+Graphite PTFE		
10	衬套 Bushing	PTFE复合轴承 Composite bearings		
11	阀体 Body	WCB	ZG1Cr18Ni9Ti	ZG1Cr18Ni12Mo2Ti
12	阀杆 Stem	1Cr13	1Cr18Ni9Ti	ZG1Cr18Ni9Ti
13	支架 Yoke	WCB	WCB	WCB
14	键 Key	45	45	45
15	衬套 Bushing	PTFE复合轴承 Composite Bearings		
16	填料 Packing	柔性石墨 PTFE Graphite PTFE		
17	压盖 Gland	WCB	ZG1Cr18Ni9Ti	ZG1Cr18Ni12Mo2Ti
18	位置指示器 Location Indicator	塑料 Plastic		

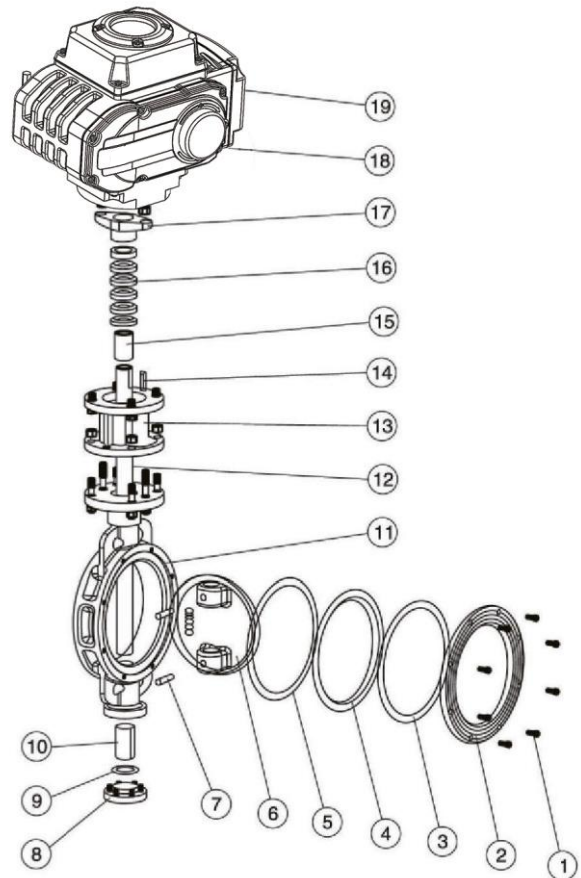

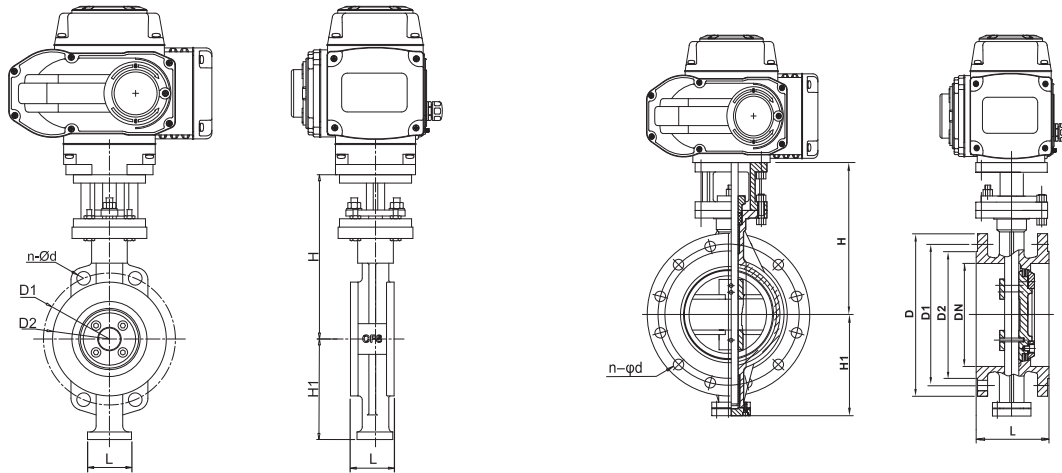

对夹连接 主要外形及连接尺寸 GB-PN16(1.6MPa) Wafer Type Main Outline and Connecting Size

MEDLE	DN80	DN100	DN125	DN150	DN200	DN250	DN300	DN350	DN400	DN450	DN500
Inch	3"	4"	5"	6"	8"	10"	12"	14"	16"	18"	20"
D	83	104.2	123.3	157	202.5	250.5	301.6	333.3	389.6	449.5	491.6
D1	160	180	210	240	295	355	410	410	525	585	620
D2	132	156	184	211	266	319	370	429	480	548	582
L	49	56	64	70	71	76	83	83	102	114	127
H	260	298	315	325	380	435	475	475	580	620	660
H1	114	128	148	170	188	235	265	265	335	380	410
n-φd	4-φ18	8-φ18	8-φ18	8-φ22	12-φ23	12-φ26	12-φ26	12-φ26	16-φ30	20-φ30	20-φ33

法兰连接 主要外形及连接尺寸 Flange Type Main Outline and Connecting Size

DN	Inch	L	1.6 MPa				2.5 MPa				150LB				300LB				High	
			D	D1	D2	Z-φd	D	D1	D2	Z-φd	D	D1	D2	Z-φd	D	D1	D2	Z-φd	H	H1
50	2"	108	165	125	102	4-φ18	165	125	102	4-φ18	150	120.7	92	4-φ19	165	127	92	8-φ19	130	96
65	2-1/2"	112	185	145	122	4/8-φ18	185	145	122	8-φ18	180	137.7	105	4-φ19	190	149.2	105	8-φ22	145	97
80	3"	114	200	160	138	8-φ18	200	160	138	8-φ18	190	152.4	127	4-φ19	210	168.3	127	8-φ22	167	108
100	4"	127	220	180	158	8-φ18	235	190	162	8-φ22	230	190.5	157	8-φ19	255	200	157	8-φ22	195	128
125	5"	140	250	210	188	8-φ18	270	220	188	8-φ26	255	215.9	186	8-φ22	280	235	186	8-φ22	240	145
150	6"	140	285	240	212	8-φ22	300	250	218	8-φ26	280	241.3	216	8-φ22	320	269.9	216	12-φ22	260	168
200	8"	152	340	295	268	12-φ22	360	310	278	12-φ26	345	298.5	270	8-φ22	380	330.2	270	12-φ26	290	190
250	10"	165	405	355	320	12-φ26	425	370	335	12-φ30	405	362	324	12-φ26	445	387.4	324	16-φ29	310	235
300	12"	178	460	410	378	16-φ26	485	430	305	16-φ30	485	431.8	381	12-φ26	520	450.8	381	16-φ32	380	266
350	14"	190	520	470	438	16-φ26	555	490	450	16-φ33	535	476.3	413	12-φ29	585	514.4	413	20-φ32	435	300
400	16"	216	580	525	490	16-φ30	620	550	505	16-φ36	595	539.8	470	16-φ29	650	571.5	470	20-φ35	460	330
450	18"	222	640	585	550	20-φ30	670	600	555	20-φ36	635	577.9	533	16-φ32	710	628.6	533	24-φ35	485	355
500	20"	229	715	650	610	20-φ33	730	660	615	20-φ36	700	635	584	20-φ32	775	685.8	584	24-φ35	520	385
600	24"	267	840	770	725	20-φ36	845	770	720	20-φ39	815	749.3	692	20-φ35	915	812.8	692	24-φ42	610	455
700	28"	292	910	840	795	24-φ36	960	875	820	24-φ42	925	863.6	800	28-φ35	1035	939.8	800	28-φ45	675	505

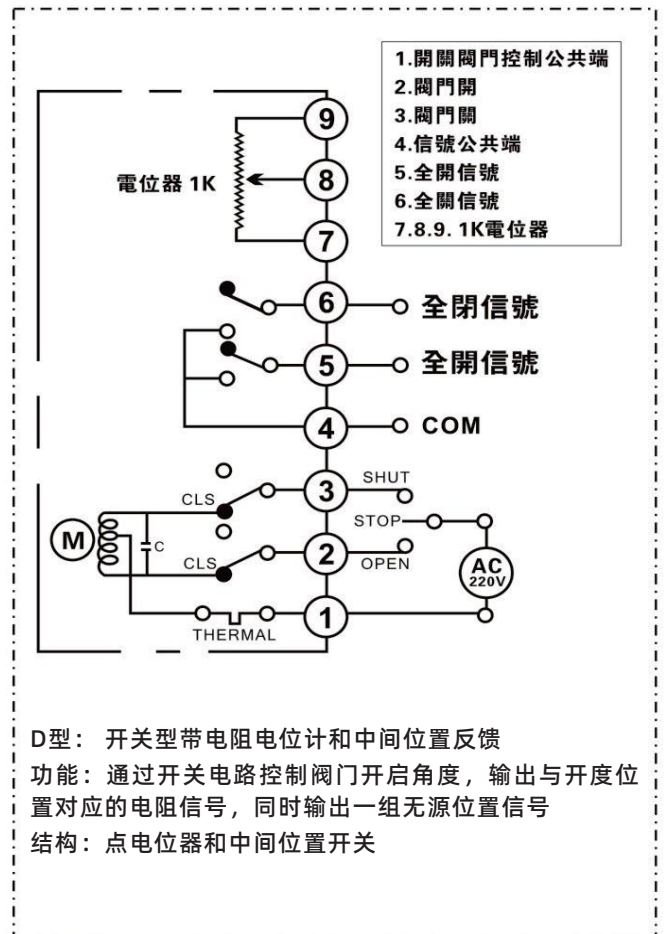
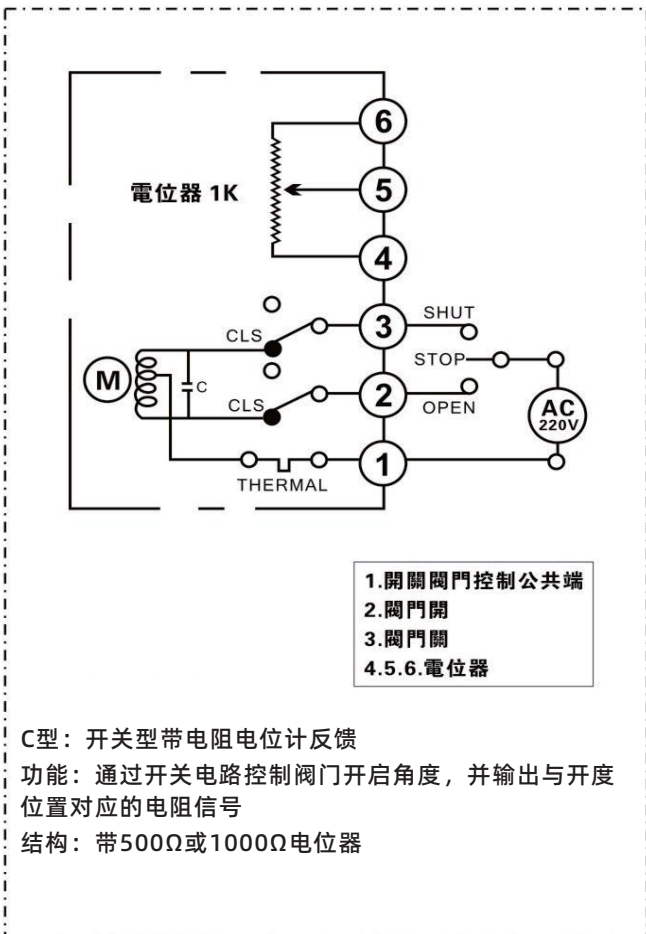
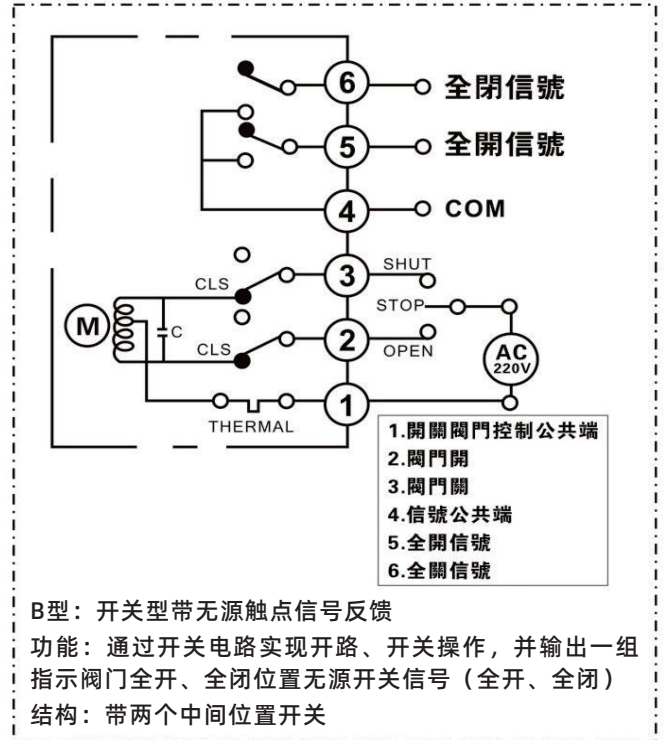
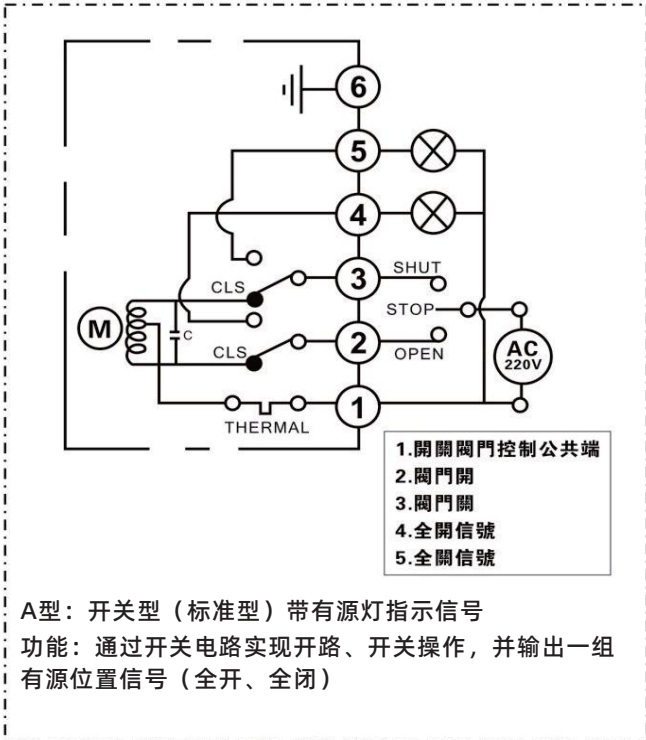

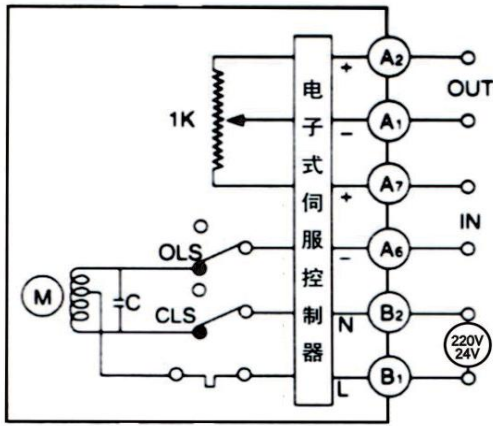

E型：调节型带伺服控制器模块  
功能：调节作用，输入/输出信号：  
4-20mA DC, 1-5V DC或0-10V DC  
结构：带控制模块和1KΩ电位器

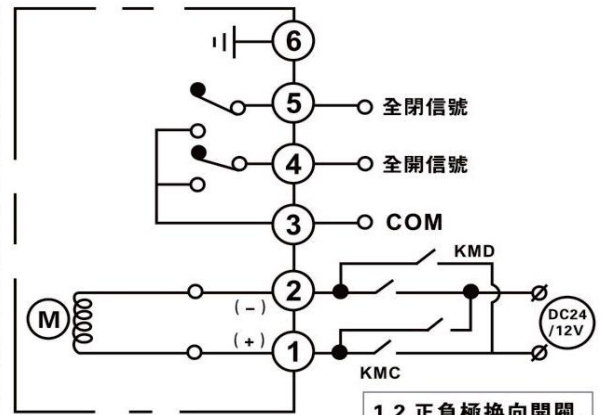

1.2.正負極換向開關，  
關閥控制  
3.信號公共端  
4.全開信號  
5.全閉信號

F型：直流电机控制电路  
功能：通过外部电路对直流电源正负极换，实现开启、开关操作并输出一组无源触点（全开、全闭）

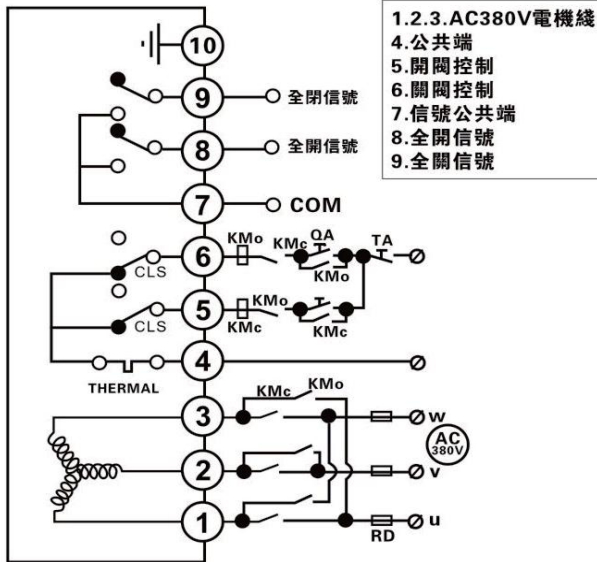

G型：三相交流380V无源触点型  
功能：通过外部倒相电路，使电机正反转实现开启、开关操作并输出一组无源触点（全开、全闭）信号  
结构：带中间位置开关

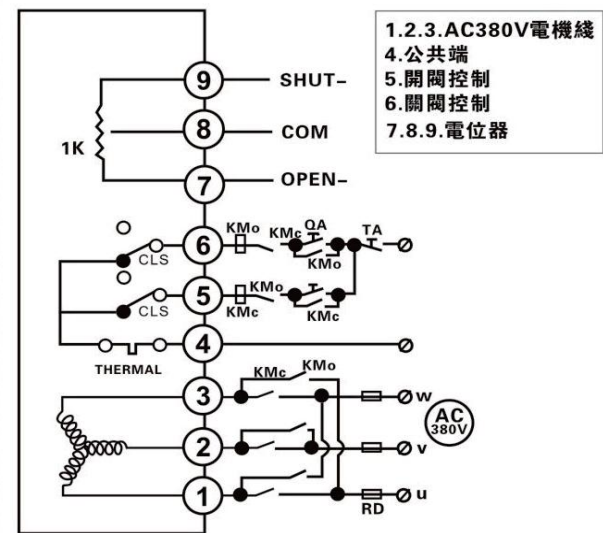

H型：三相交流380V开度信号型  
功能：通过外部倒相电路，使电机正反转实现开启、关闭操作并输出一组无源触点（全开、全闭）信号  
结构：带中间位置开关

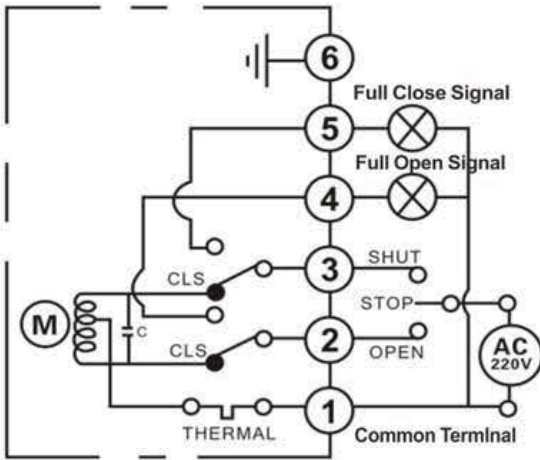

**A: ON/OFF Type with Light Indicator Signal Feedback**

**Function:** Finish open or close operations by the circuit, and the actuator outputs a signal of active position (full opening, full closing)

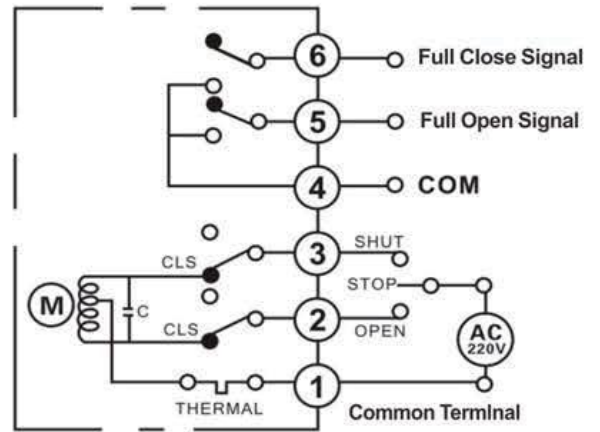

**B: ON/OFF Type with Passive Contact Signal Feedback**

**Function:** Finish open or close operations by the circuit, and the actuator outputs a set signal of passive position (full opening, full closing)

**Structure:** with two neutral positions switches

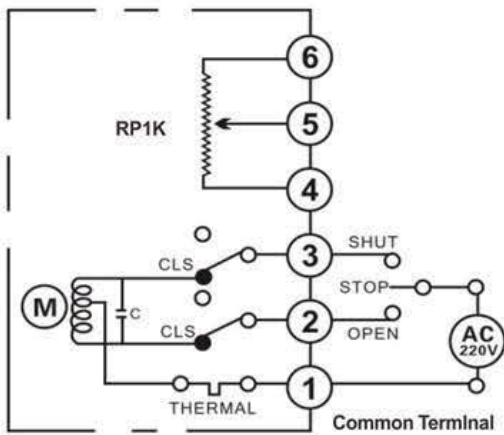

**C: ON/OFF Type with Resistance Potentiometer Signal Feedback**

**Function:** Control the open angle of valves by circuit, and the actuator outputs the resistance signal corresponding to the position of switch

**Structure:** with 500Ω or 1000Ω potentiometer

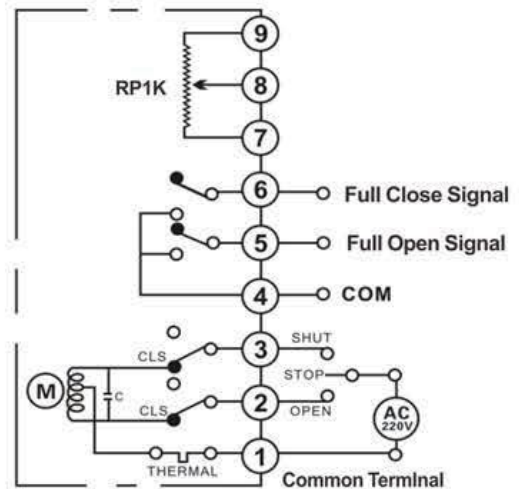

**D: ON/OFF Type with Resistance Potentiometer and Neutral Position Signal Feedback**

**Function:** control the open angle of valves by circuit, and the actuator outputs the resistance signal corresponding to the position of open position, at the same time, outputting a set signal of passive position

**Structure:** both potentiometer style and neutral positions switch style

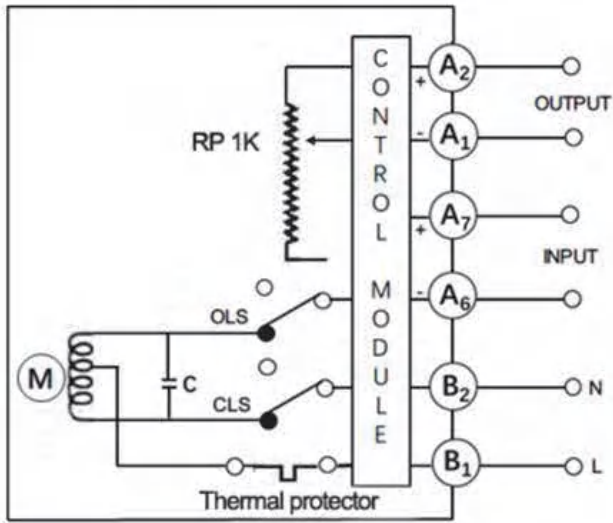

**E: Regulation Type with Servo Control Module**

**Function:** Modulating, input & output  
DC4-20mA, 1-5VDC, 0-10VDC

**Structure:** With servo control module and  
1000Ω potentiometer

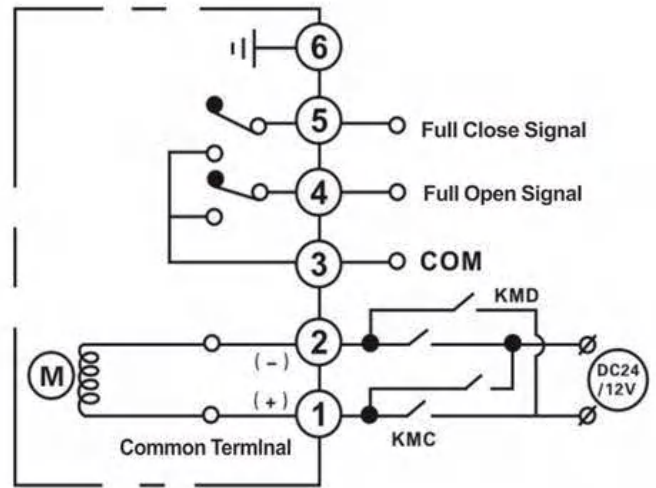

**F: DC24V/ DC12V Direct ON-OFF Type**

**Function:** The external circuit make positive and negative conversion of DC power to open or close, and the actuator outputs a set signal of passive position (full opening, full closing),

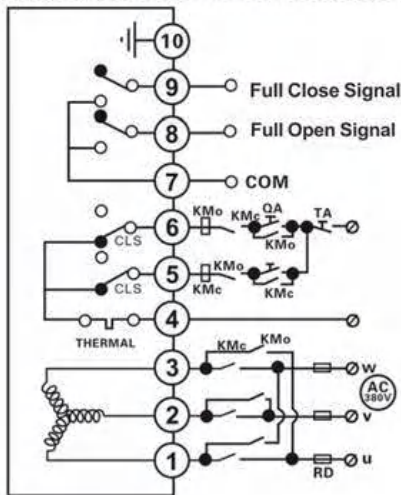

**G: AC380V Three-Phase Power Supply with Passive Signal Feedback**

**Function:** The external circuit make positive and negative conversion of DC power to open or close, and the actuator outputs a set signal of passive position (full opening, full closing)

**Notes:**

Please kindly note if the switch position is correct when the three phase electric actuator is being adjusted, if it's opposite direction, then make 2 of power lines exchange each other

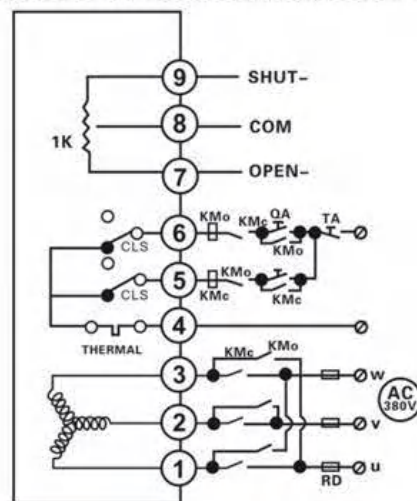

**H: AC380V Three-Phase Power Supply with Resistance Potentiometer Signal Feedback**

**Function:** The external circuit make positive and negative conversion of DC power to open or close, and the actuator outputs a set signal of passive position (full opening, full closing)

**Notes:**

Please kindly note if the switch position is correct when the three phase electric actuator is being adjusted, if it's opposite direction, then make 2 of power lines exchange each other

### VINCER-05

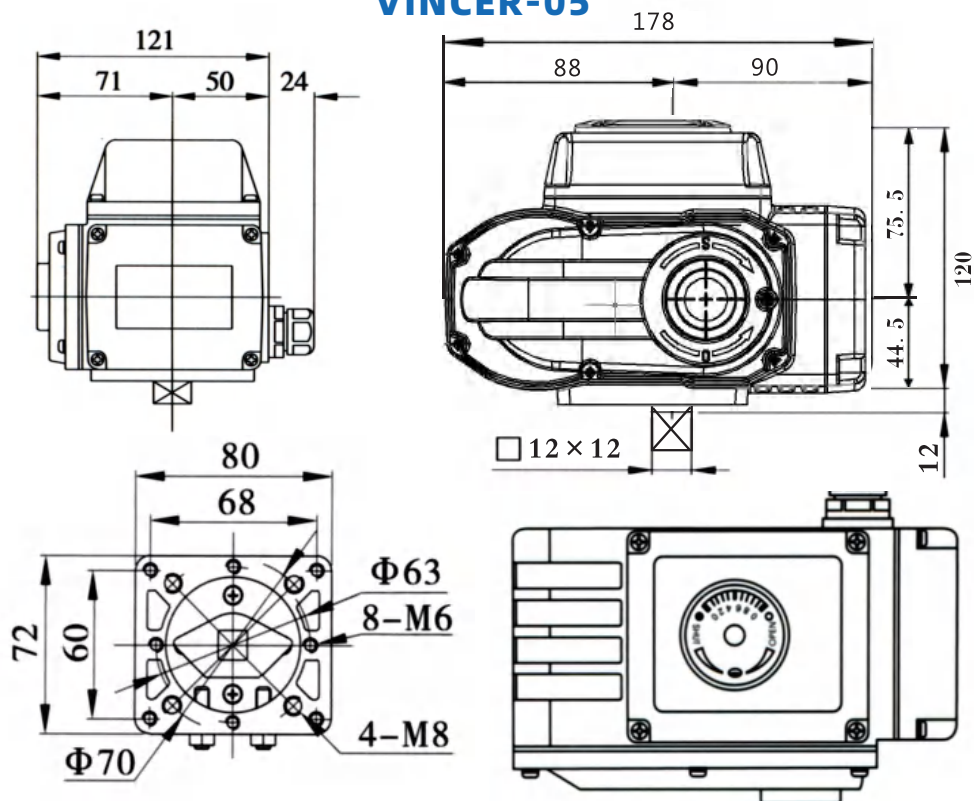

### VINCER-10/16

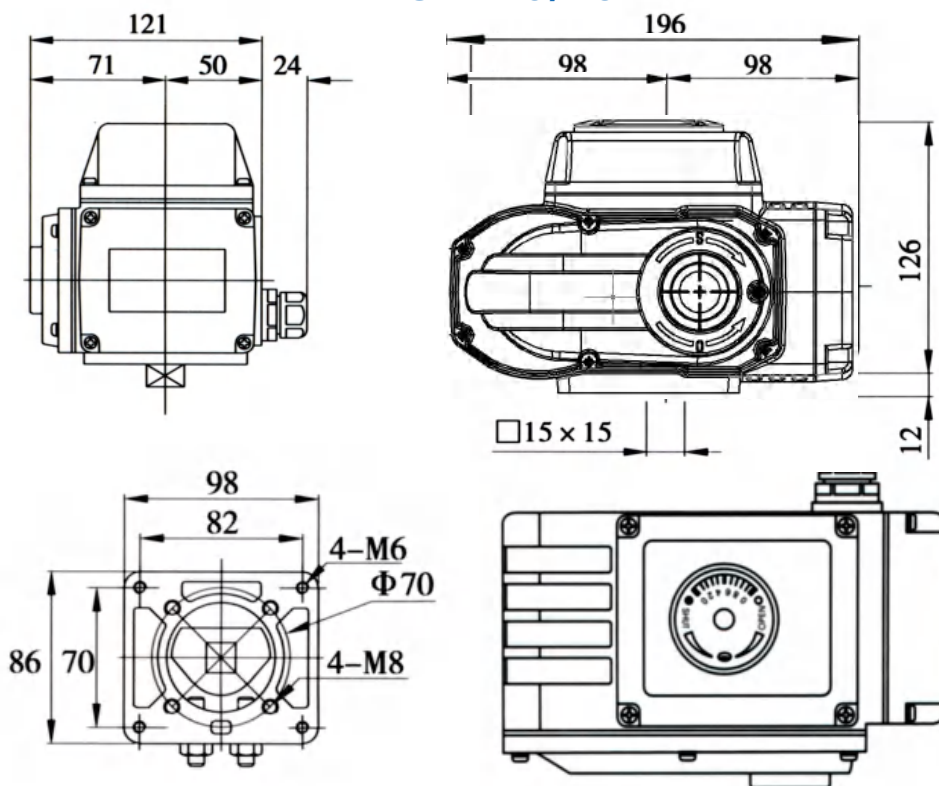



**VINCER-30/60**

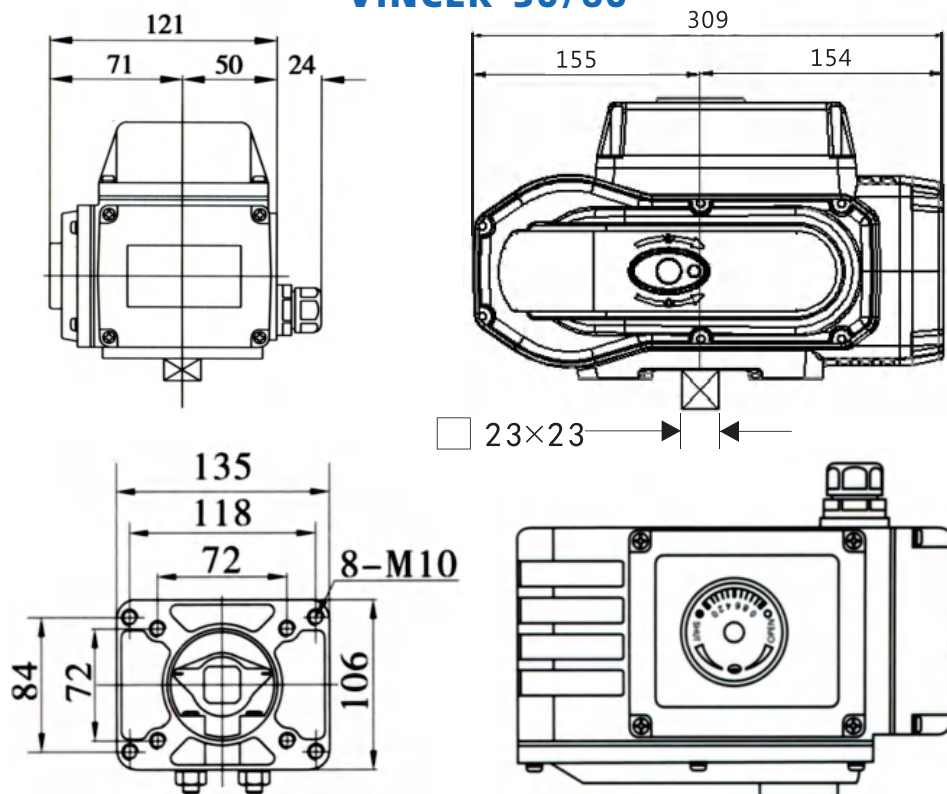

**VINCER-125/250/400**

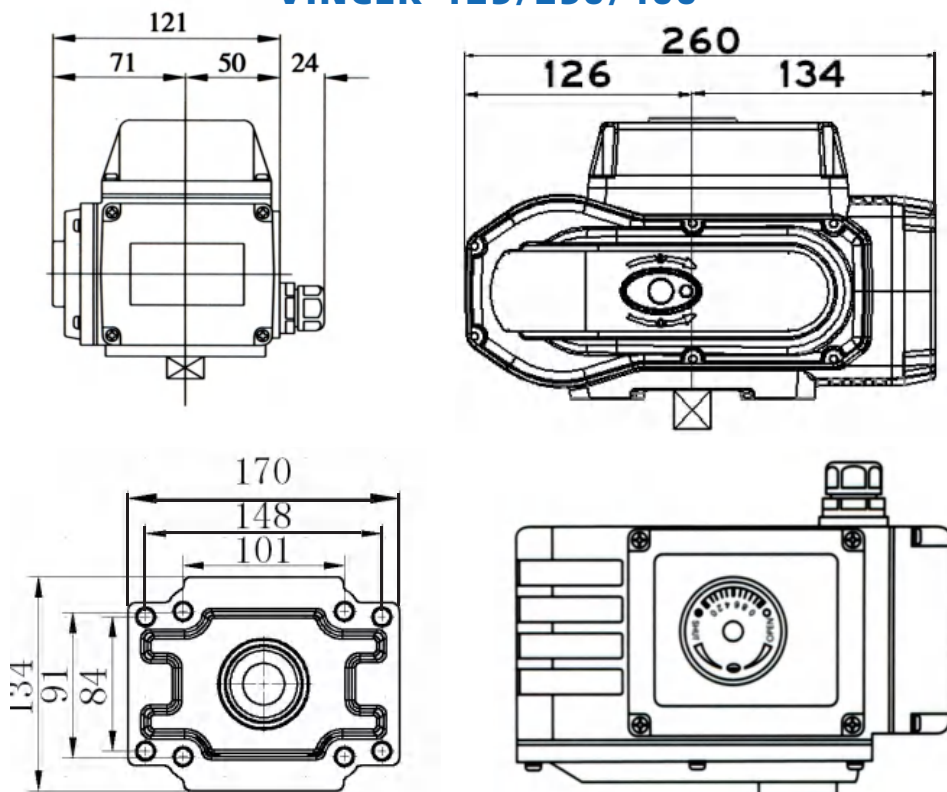

**安装环境 Installation environment**

- 1、本产品既可在室内安装，也可在室外安装，周边环境温度-30°C~+60°C范围内。
- 2、本产品属非防爆产品，请注意避开易燃易爆等环境。
- 3、在长期有雨水、原料等飞溅物和阳光直射的环境，需要安装保护整体的盖子。
- 4、请预留接线，手动操作等维修用空间。

The product can be installed indoor and outdoor, The surrounding environment temperature should be in-30°C~+60°C. Product is non-explosion-proof production, and the installation must be avoided being in flammable or explosive environment etc. The actuator should be in protection box in the environment of long-term with the splash of rain, material and direct sunlight. Please reserve space for controller, manual operation.

**工作介质温度 Temperature of working medium**

- 1、与阀门配套使用时，工作介质温度传到机体上面，机体温度会升高。
- 2、工作介质是高温时与阀门连接的支架器，减少热传导作用。

When matching with the valve, the actuator body's temperature will a bit rise if medium temperature happen heat transfer. If the temperature of medium is high, the bracket has the function of reducing heat conduction.

**安装在阀门上 Installed on the valve body**

- 1、手动转动阀门，确定无异常情况，并使用阀门处于全闭位置。
- 2、将联轴器一端套在阀门芯轴上。
- 3、将电动执行器机体转到全闭位置，出力轴插入联轴器四方孔内。
- 4、紧固电动执行器机体和阀门平台间的螺钉。
- 5、用手柄转动执行器机构，确认运行平稳，无偏心，无歪斜。注意不要超程。

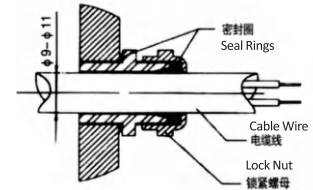

Manually operate the actuator to drive the valve, confirm it does not have abnormal situation. Turn the valve in full closed position. Set one end of couplings on valve spindle. Turn the electric actuator to full closing position, and insert output-input shaft into the square holes of couplings. Set the screw between the electric actuator and valve body. Turn actuator by hand shank, confirm that it moves translation, no eccentric, no skew and no overrun.

**安装电缆线 Cable installation**

- 1、用电缆管时，电缆管外径是  $\phi 9 \sim \phi 11$ ，要充分采取防水对策，执行器机体高于电线管，磁电线管内水珠不至流进执行器机体以确保其安全。
- 2、使用电缆时，其外径是  $\phi 9 \sim \phi 11$  的电缆。一律不准使用与电阻直径不相应的电缆，否则水珠可能从线索进入执行机构内，损坏所有内部零件。
- 3、信号线原则上要使用屏蔽线，不要与动力线平行配线。

Install wire tubes, The outside diameter of wire tubes should be  $\phi 9 - \phi 11$ . Take measures to proof water. To prevent actuator from flowing into wire tubes water, the actuation position should higher than wire tubes position.

When installing wire, the outside diameter of wire should be  $\phi 9 - \phi 11$ . in case the water flow into actuator interior from line locking, all wire that are not allowed to be used.

The signal wire should be shielded wire in principle, don't parallel it to power wire.

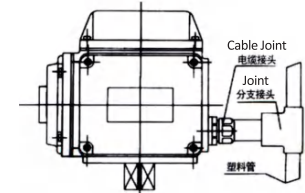

**特别提示 Special tips**

不要将两台或数台电动装置的动力线并联，也就是不能用同一接线去控制多台电动装置，否则会造成失控，会电机过热及产品损坏等，会大大影响电动装置的使用寿命。如电动装置是安装在户外时，建议加装防雨、防护罩，这样能使电动机构的使用性能更稳定，寿命更长久。

Caution: can't connect one actuator parallel with one another, in other words, can't use the same controller contact point to control more than one actuator, otherwise it will cause out of control, motor overheating, product damage, shorter service life. If the actuator is installed outdoor, we suggest equippine other protective cover to proof water, stabilize mechanical property, make a longer service life.

### 极限位置开关的调整 Adjustment of limit position switch

- 1、将阀门手动至全闭位置。
- 2、松开行程档块固定螺钉，转动下面板块，使下面形成开关动作，微动开关动作时会发出“咔嚓”声音，然后固定螺钉。
- 3、全开位置调整方法同上。

Turn the valve to full opening position by hand.

Loosen the screw of travel block and turn the block to drive the travel switch, then fine-tuning sensitive switch until hearing "click", after that, set screw.

The way of adjustment full opening position is the same as above.

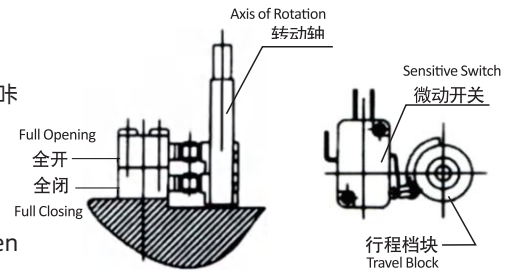

### 中间位置开关的调整 Adjustment of middle position switch

- 1、用手柄驱动阀门至所需位置。
- 2、松开行程档块固定螺钉，转动行程档块是相对应的微动开关动作，然后固定螺钉。
- 3、两个中间位置开关动作位置可根据使用需要进行调整。

Use hand shank to drive the valve to the position it need.

Loosen the screw of travel block and turn the travel block to drive sensitive switch, then set screw.

These two neutral position switches' position could be adjusted according to need.

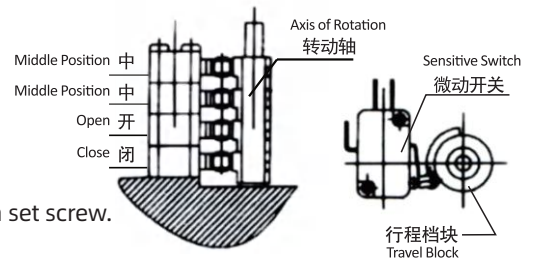

### 定位器的调整 Adjustment of potentiometer

- 1、用手柄驱动执行机构向中间位置运行,使指针正指50%刻度线。
- 2、用万用表测量电位器始端和终端阻值(电位器1.3两角间阻值),记下阻值R(如无特别要求,电位器的出厂默认为 $1K\Omega \pm 15\%$ )。
- 3、用适当外力作用在电位器安装板上,使开度齿轮和电位器齿轮脱离咬合。
- 4、将万用表两表笔分别接在电位器动臂(电位器两脚)和另外任意一端上,缓缓转动电位器齿轮,观察万用表读数,当阻值 $R/2 \pm 2\Omega$ 时,停止调整并撤销外力使开度齿轮与电位器齿轮回复咬合即可。

Use hand shank to drive actuator to neutral position, and turn the pointer point to 50% scale line.

Use multimeter to test resistance of first and third port of potentiometer (resistance between the first port and third port in potentiometer), and mark R(potentiometer default is  $1K\Omega \pm 15\%$  if no special request).

Separate potentiometer gear from the opening gear by suitable external force on potentiometer fixing plate.

Put one probe of multimeter to one potentiometer termina, the other probe to another terminal, then rotate potentiometer gear and see number in multimeter .When the resistance value is equivalent to  $R/2 \pm 2\Omega$ , stop rotating, after that, mesh these two gears.

### 机械档块的调整 Adjustment of mechanical limit location block

- 1、用手柄驱动阀门至全开位置,并使全开位置开关动作(微动开关动作时会发出“咔嚓”声音)
- 2、松开锁紧螺母,使调整螺钉与机械档块相接触,然后将调整螺钉往回转动半圈,锁紧螺母。
- 3、用同样的方法进行全闭位置的调整。

Use hand shank to drive valve to full opening position and operate the switch (sensitive switch makes crack sound when it is running).

Loosen the nut and turn the adjusting screw to touch the mechanical limit location block, then turn the adjusting screw a half turn back, set nut.

Adjusting the full opening position by the same way as above.



一、本产品出厂前已经过全面调试，实际安装时，因阀门、联轴器等原因有可能无法满足您的使用要求，重新调试时请遵循如下程序：

1.将执行机构与阀门正确安装在一起；

2.卸下电装盖，根据阀门实际状况进行如下测试：

极限位置开关的调整；

中间位置开关的调整；

调节性调试（仅针对e型机，参见调节型调试）；机构挡块的调整。

3.手动试运转：

摘下驱动盖橡胶帽，将手柄插入六角孔按顺时针方向转动使阀门开度减小；

检查全闭位置极限开关是否动作（微动开关动作时会发出“咔嚓”声音），再转动约半圈检查限位螺丝是否碰上机械挡块；

按逆时针方向转动使阀门开度增大，同样的检查全开位置极限开关动作情况和机械挡块限位情况。手动试运转完毕后，请盖上顶部电装盖。

电动试运转：

卸下制御盖，并按制御盖上回路图正确接线；

在顺时针、逆时针两个方向通电试运转，并注意观察执行机构和阀门工作是否正常。

**1.This product has been fully debugged before leaving the factory, and during the actual installation, it may not be able to meet your requirements due to valves, couplings and other reasons, please follow the following procedures when re-commissioning:**

①. Install the actuator and the valve together correctly;

②. Remove the electrical cover and perform the following tests according to the actual condition of the valve:

Adjustment of limit position switches;

Adjustment of the intermediate position switch;

Adjustable debugging (only for E-type machines, see Adjustable Debugging);

③. Manual test run:

Take off the rubber cap of the drive cover, insert the handle into the hexagonal hole and rotate it in a clockwise direction to reduce the opening of the valve;

Check whether the limit switch in the fully closed position is in action (the micro switch will make a "click" sound when it moves), and then turn about half a turn to check whether the limit screw touches the mechanical stopper;

Rotate in the counterclockwise direction to increase the opening of the valve, and check the action of the limit switch in the fully open position and the limit of the mechanical stop. After the manual test run is completed, please close the top electrical cover.

Electric commissioning:

Remove the royal cover, and wire correctly according to the circuit diagram on the royal cover;

In the clockwise and counterclockwise directions, the power is turned on for trial operation, and attention is paid to observe whether the actuator and valve are working normally.

## 二、维护与保养

由于使用了寿命长、耐压性好的钼基滑脂，所以不需加油；

在阀门的动作很稀少时，请定期驱动机器，检查有无异常。

## 2.Maintenance and maintenance

Because of the use of molybdenum-based grease with long life and good pressure resistance, there is no need to add oil;

When the operation of the valve is scarce, drive the machine regularly to check for abnormalities.



## 三、故障与对策

## Failures and countermeasures

故障现象 Fault phenomenon	故障原因 Cause of the failure	解决办法 Solution
电机不启动 The motor does not start	没有接上电源 Not plugged in	接好电源 Plug it in
	断线、接头与端子脱离 The wire is broken and the connector is disconnected from the terminal	修理断线，正确连接坚固端子 Repair the broken wire and connect the sturdy terminals correctly
	电源电压不对或电压过低 The power supply voltage is not right or the voltage is too low	检查电压是否正常 Check if the voltage is normal
	过热保护器动作 Overheat protector action	降低环境温度，检查阀门开关是否正常 Reduce the ambient temperature and check if the valve switch is normal
	极限开关的动作不良 The operation of the limit switch is not good	更换开关 Replace the switch
	启动运行动作不良 Poor start-up operation	与厂家联系更换电容 Contact the manufacturer to replace the capacitor
开关指示灯不亮 The switch indicator is not on	坏灯泡 Bad bulbs	更换灯泡 Replace the bulbs
	极限开关动作不良 Poor operation of the limit switch	更换开关 Replace the switch
	挡块的调整不良 Poor adjustment of the stopper	再调整 readjustment
开关不停地来回变化 The switch keeps changing back and forth	信号源里有干扰信号 There is an interfering signal in the signal source	检查输入信号 Check the input signal
	从分压器里产生干扰 Interference from the voltage divider	更换电位器 Replace the potentiometer
	分压器齿轮或开度齿轮松动 Loose distributor gear or opening gear	检查固定齿轮的螺钉 Check the screws that hold the gears in place



**VINCER VALVE**  
VALVE AUTOMATION TECHNOLOGY

VINCER

## GET IN TOUCH VALVE CONSULTANT

**Hebe Wong**

+86 13826949015

[www.vincervalve.com](http://www.vincervalve.com)

地址：广东省东莞市东城街道樟村大园路110号1号楼203室  
Address: Room No. 203, Building No.1, Zhangcun  
Dayuan Road No. 110, Dongcheng District,  
Dongguan City, Guangdong Province



QUALITY VALVE AND UNBEATABLE VALUE